



FOUNDRY
COMMERCIAL

MULTIFAMILY PROPERTY FOR SALE

1926-1942 FORTUNA AVENUE, SAN DIEGO, CA 92109

3,949± SF ON 0.17± AC FOR SALE



DESCRIPTION

The subject property is located on Fortuna Avenue at the corner of Honeycutt Street in the Mission Bay district of San Diego, CA. Located just 0.25 miles from Crown Point Park and less than 10 minutes from Pacific Beach, the property is positioned with great access to some of San Diego’s best attractions, including Sea World San Diego and Fiesta Island.

The property is currently used as a multifamily facility and comprised of three buildings containing eight units totaling approx. 3,949± SF, with approx 0.17± acres of land.

BUILDING FEATURES

BUILDING SIZE	3,949± SF Total
ACREAGE	0.17± AC
USE	Multi-family Residential
ZONING	RM-1-1 Residential Multi-Unit
YEAR BUILT	Est. 1955
COUNTY	San Diego
APN	424-431-14-00
PRICE	Call for Details

FOR MORE INFORMATION, PLEASE CONTACT:

CHRIS BURY | 949.939.6238
 Partner, Senior Vice President
 Chris.Bury@foundrycommercial.com
 Licensed Real Estate Broker

CHARLIE HOWARTH | 949.542.9484
 Senior Associate
 Charlie.Howarth@foundrycommercial.com
 Licensed Real Estate Broker



PROPERTY OUTLINE & MAP

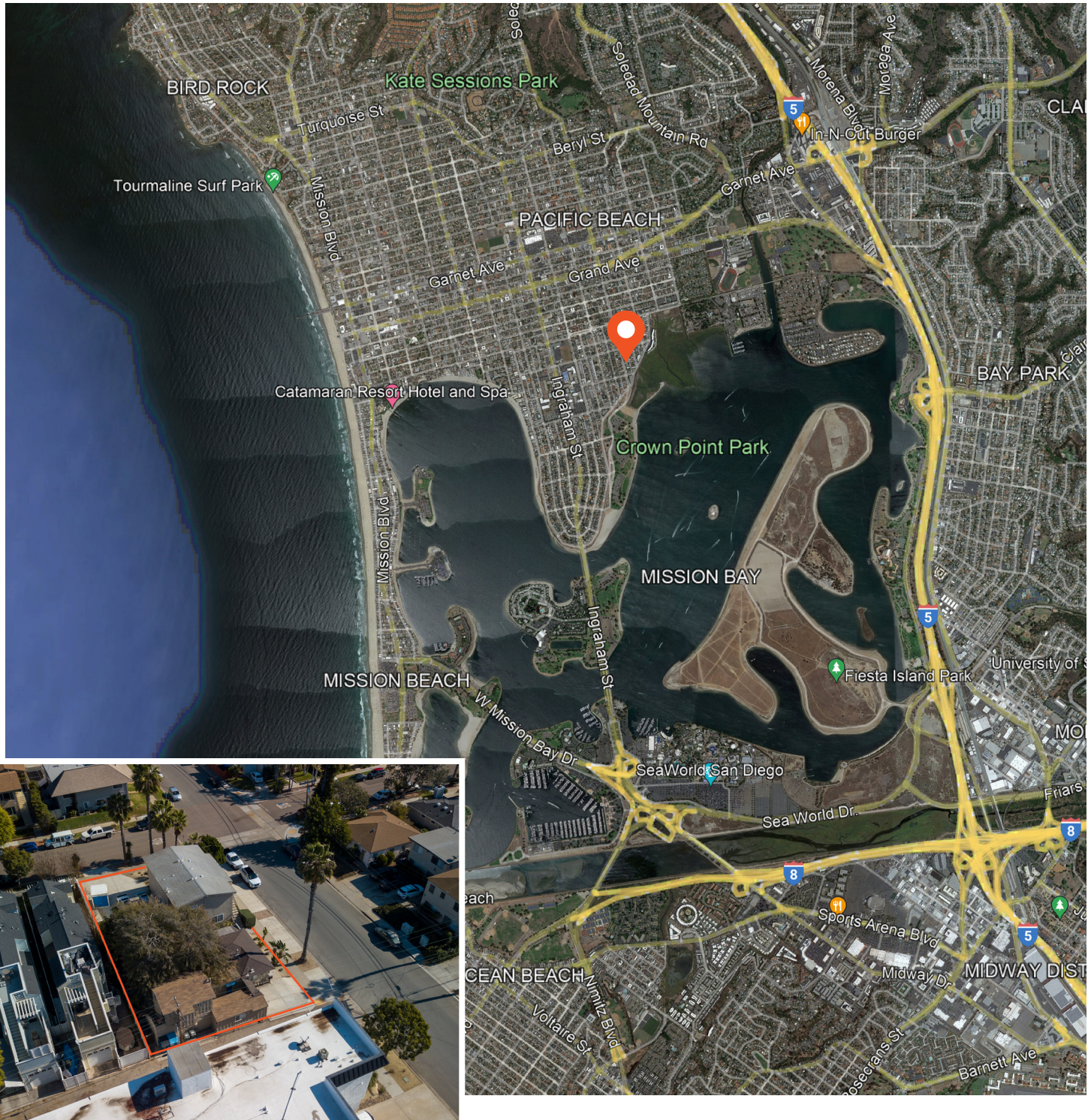

FOR MORE INFORMATION, PLEASE CONTACT:

CHRIS BURY | 949.939.6238
 Partner, Senior Vice President
 Chris.Bury@foundrycommercial.com
 Licensed Real Estate Broker

CHARLIE HOWARTH | 949.542.9484
 Senior Associate
 Charlie.Howarth@foundrycommercial.com
 Licensed Real Estate Broker



MISSION
PROPERTY
GROUP

Although all information furnished regarding for sale, rental or financing is from sources we deem reliable, such information has not been verified and no express representation is made nor is any to be implied as to the accuracy thereof, and it is submitted subject to errors, omissions, changes of price, rental or other conditions, prior sale, lease or financing, or withdrawal without notice. All sizes are approximate and subject to survey.

BUILDINGS & UNITS



UNIT	LEVEL	BEDROOMS	BATHROOMS	SIZE (SF)
1926-A	1	1	1	559 SF
1926-B	1	1	1	564 SF
1926-C	2	1 (Studio)	1	226 SF
1926-D	1	1	1	424 SF
1936	1	1	1	544 SF
1938	1	1	1	544 SF
1940	2	1	1	544 SF
1942	2	1	1	544 SF
TOTALS		8	8	3,949 SF

FOR MORE INFORMATION, PLEASE CONTACT:

CHRIS BURY | 949.939.6238
 Partner, Senior Vice President
 Chris.Bury@foundrycommercial.com
 Licensed Real Estate Broker

CHARLIE HOWARTH | 949.542.9484
 Senior Associate
 Charlie.Howarth@foundrycommercial.com
 Licensed Real Estate Broker



SITE PLAN

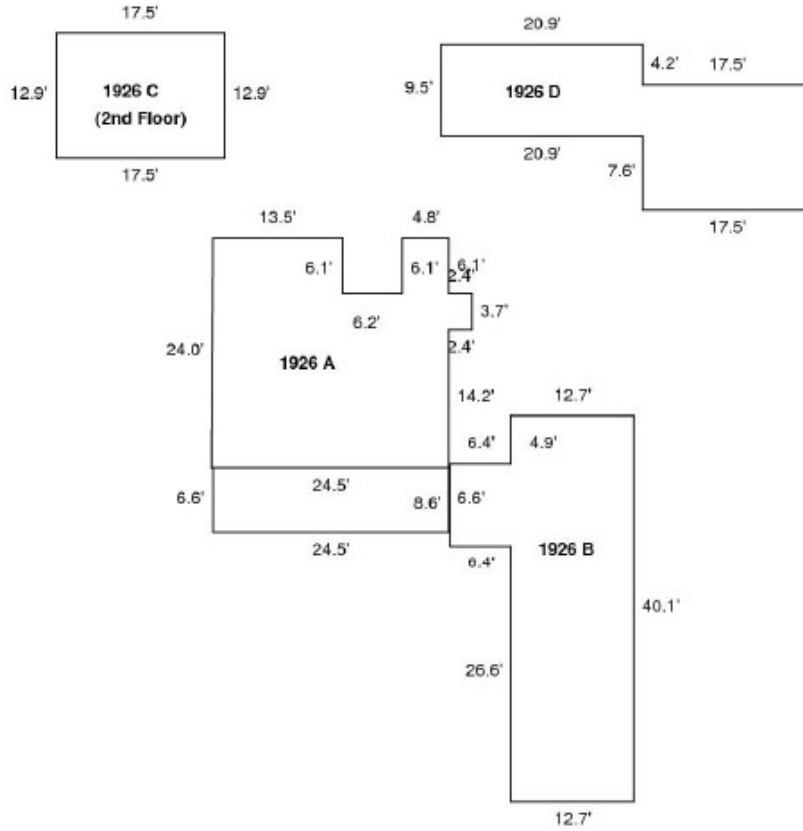

FIRST FLOOR

SECOND FLOOR

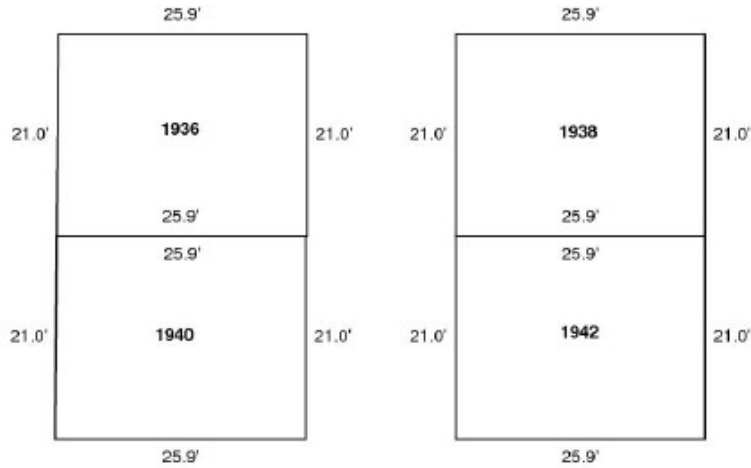

FOR MORE INFORMATION, PLEASE CONTACT:

CHRIS BURY | 949.939.6238
 Partner, Senior Vice President
 Chris.Bury@foundrycommercial.com
 Licensed Real Estate Broker

CHARLIE HOWARTH | 949.542.9484
 Senior Associate
 Charlie.Howarth@foundrycommercial.com
 Licensed Real Estate Broker



MISSION
 PROPERTY
 GROUP

PHOTOS



FOR MORE INFORMATION, PLEASE CONTACT:

CHRIS BURY | 949.939.6238
Partner, Senior Vice President
Chris.Bury@foundrycommercial.com
Licensed Real Estate Broker

CHARLIE HOWARTH | 949.542.9484
Senior Associate
Charlie.Howarth@foundrycommercial.com
Licensed Real Estate Broker

FOUNDRY
COMMERCIAL

MISSION
PROPERTY
GROUP

Although all information furnished regarding for sale, rental or financing is from sources we deem reliable, such information has not been verified and no express representation is made nor is any to be implied as to the accuracy thereof, and it is submitted subject to errors, omissions, changes of price, rental or other conditions, prior sale, lease or financing, or withdrawal without notice. All sizes are approximate and subject to survey.

foundrycommercial.com

PHOTOS



FOR MORE INFORMATION, PLEASE CONTACT:

CHRIS BURY | 949.939.6238
Partner, Senior Vice President
Chris.Bury@foundrycommercial.com
Licensed Real Estate Broker

CHARLIE HOWARTH | 949.542.9484
Senior Associate
Charlie.Howarth@foundrycommercial.com
Licensed Real Estate Broker

FOUNDRY
COMMERCIAL

MISSION
PROPERTY
GROUP

Although all information furnished regarding for sale, rental or financing is from sources we deem reliable, such information has not been verified and no express representation is made nor is any to be implied as to the accuracy thereof, and it is submitted subject to errors, omissions, changes of price, rental or other conditions, prior sale, lease or financing, or withdrawal without notice. All sizes are approximate and subject to survey.

foundrycommercial.com

DEMOGRAPHICS

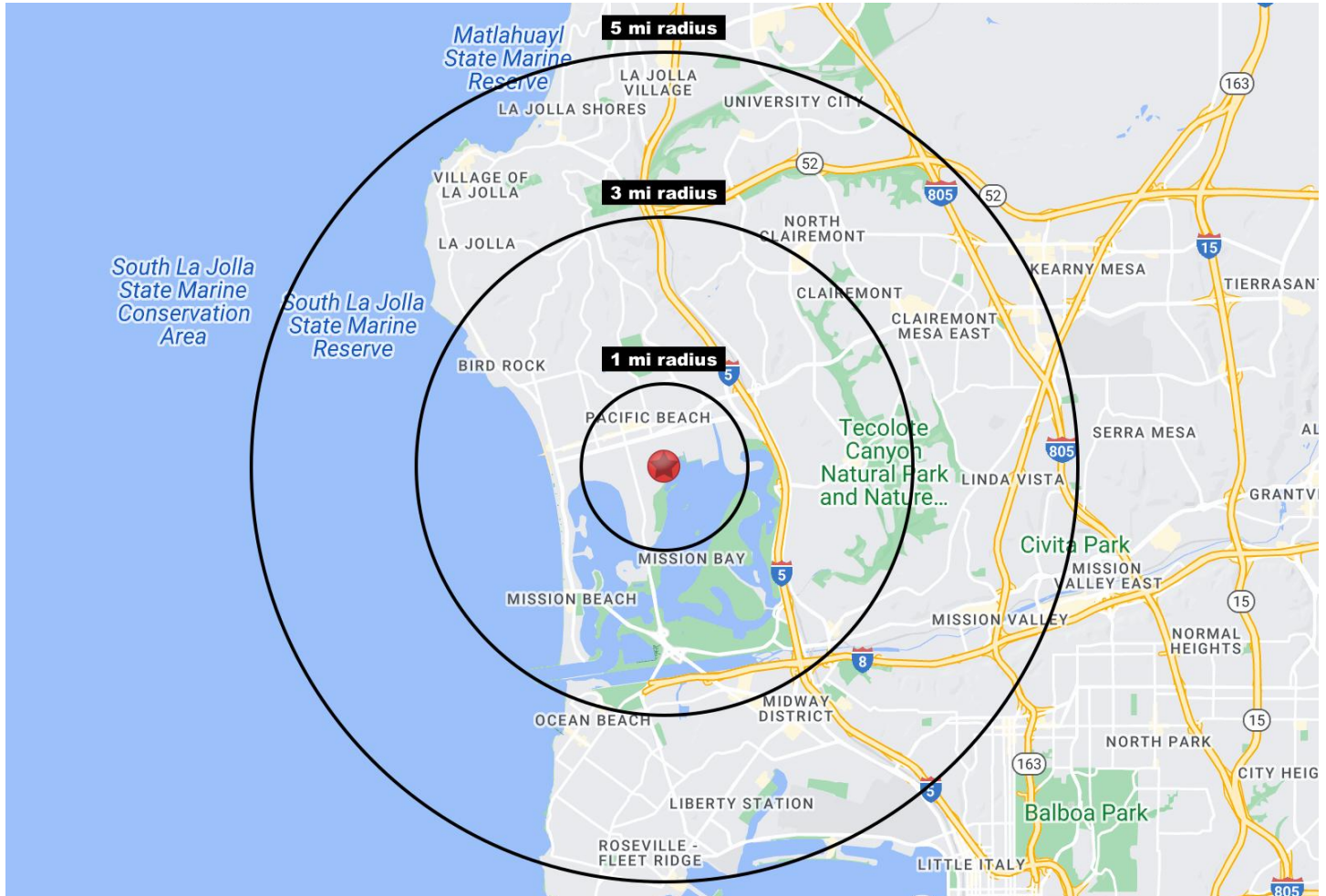

1 MILE RADIUS

	24,925 ESTIMATED POPULATION 2022
	32.4 MEDIAN AGE
	\$864,641 MEDIAN HOME VALUE 2022
	6,342 TOTAL EMPLOYEES
	\$105,571 AVG HOUSEHOLD INCOME

3 MILE RADIUS

	103,571 ESTIMATED POPULATION 2022
	38.2 MEDIAN AGE
	\$982,661 MEDIAN HOME VALUE 2022
	51,093 TOTAL EMPLOYEES
	\$130,629 AVG HOUSEHOLD INCOME

5 MILE RADIUS

	297,244 ESTIMATED POPULATION 2022
	38.4 MEDIAN AGE
	\$959,047 MEDIAN HOME VALUE 2022
	172,263 TOTAL EMPLOYEES
	\$129,589 AVG HOUSEHOLD INCOME

FOR MORE INFORMATION, PLEASE CONTACT:

CHRIS BURY | 949.939.6238
Partner, Senior Vice President
Chris.Bury@foundrycommercial.com
Licensed Real Estate Broker

CHARLIE HOWARTH | 949.542.9484
Senior Associate
Charlie.Howarth@foundrycommercial.com
Licensed Real Estate Broker



MISSION
PROPERTY
GROUP

Although all information furnished regarding for sale, rental or financing is from sources we deem reliable, such information has not been verified and no express representation is made nor is any to be implied as to the accuracy thereof, and it is submitted subject to errors, omissions, changes of price, rental or other conditions, prior sale, lease or financing, or withdrawal without notice. All sizes are approximate and subject to survey.